

EDITOR  
Schwartz

EDITOR  
Grant

KIRK-OTHMER

# ENCYCLOPEDIA OF CHEMICAL TECHNOLOGY

FOURTH EDITION

VOLUME 16

MASS TRANSFER  
TO  
NEUROREGULATORS



A Wiley-Interscience Publication  
**JOHN WILEY & SONS**

New York • Chichester • Brisbane • Toronto • Singapore

This text is printed on acid-free paper.

Copyright © 1995 by John Wiley & Sons, Inc.

All rights reserved. Published simultaneously in Canada.

Reproduction or translation of any part of this work beyond that permitted by Sections 107 or 108 of the 1976 United States Copyright Act without the permission of the copyright owner is unlawful. Requests for permission or further information should be addressed to the Permissions Department, John Wiley & Sons, Inc., 605 Third Avenue, New York, NY 10158-0012.

**Library of Congress Cataloging-in-Publication Data**

Encyclopedia of chemical technology/executive editor, Jacqueline I. Kroschwitz; editor, Mary Howe-Grant.—4th ed.  
p. cm.

At head of title: Kirk-Othmer.

"A Wiley-Interscience publication."

Includes index.

Contents: v. 16, Mass Transfer to neuroregulators

ISBN 0-471-52685-1 (v. 16)

I. Chemistry, Technical—Encyclopedias. I. Kirk, Raymond E.

(Raymond Eller), 1890–1957. II. Othmer, Donald F. (Donald

Frederick), 1904– . III. Kroschwitz, Jacqueline I., 1942– .

IV. Howe-Grant, Mary, 1943– . V. Title: Kirk-Othmer encyclopedia of chemical technology.

TP9.E685 1992

91-16789

660'.03—dc20

**Printed in the United States of America**

10 9 8 7 6 5 4 3 2

130. U.S. Pat. 3,147,222 (Sept. 1, 1964), L. N. Bauer (to Rohm and Haas Co.).  
 131. U.S. Pat. 3,879,304 (Apr. 22, 1975), J. O. Waldbilling (to Texaco, Inc.).  
 132. A. S. Wood, *Mod. Plast.* **52**, 40 (Aug. 1975).  
 133. *Mod. Plast.* **49**, 44 (Aug. 1972).  
 134. R. Martino, *Mod. Plast.* **51**, 62 (Nov. 1974).  
 135. G. Kuhl and H.-D. Christian, *Pigment Resin Technol.* **16**(7), 4 (1987).

RONALD W. NOVAK  
 PATRICIA M. LESKO  
 Röhm and Haas Company

**METHANE.** See HYDROCARBONS.

## METHANOL

Methanol [67-56-1] (methyl alcohol),  $\text{CH}_3\text{OH}$ , is a colorless liquid at ambient temperatures with a mild, characteristic alcohol odor. Originally called wood alcohol since it was obtained from the destructive distillation of wood, today commercial methanol is sometimes referred to as synthetic methanol because it is produced from synthesis gas, a mixture of hydrogen and carbon oxides, generated by a variety of sources.

Methanol has traditionally been used as a solvent and as a feedstock for bulk organic chemicals (primarily formaldehyde), with modest growth potential. However, after 1990, demand for methanol as a feedstock for methyl *tert*-butyl ether [1634-04-4] (MTBE) accelerated when the latter became a significant oxygenated component in motor fuels. As a result, methanol has evolved into a globally produced and traded commodity with expected future growth in the alternate and oxygenated fuel sectors, driven by both strategic and environmental considerations.

### Physical Properties

Important physical properties of methanol are given in Table 1. Methanol is miscible with water, other alcohols, esters, ketones, ethers, and most organic solvents. Methanol has a particular affinity for carbon dioxide and hydrogen sulfide, which is the basis for its use as the solvent in the Rectisol gas sweetening process. Being polar in nature, methanol often exhibits nonideal behavior with hydrocarbons, forming azeotropes with many compounds (2). Methanol depresses the formation temperature of natural gas hydrates, leading to its use as an antifreeze in pipelines.

Table 1. Physical Properties of Methanol

Property	Value
boiling point, °C	64.70
critical temperature, °C	239.43
critical pressure, kPa <sup>a</sup>	8096
critical volume, mL/mol	118
critical value of compressibility factor	0.224
heat of formation (liquid) at 25°C, kJ/mol <sup>b</sup>	-239.03
free energy of formation (liquid) at 25°C, kJ/mol <sup>b</sup>	-166.81
heat of fusion, J/g <sup>b</sup>	103
heat of vaporization at boiling point, J/g <sup>b</sup>	1129
heat of combustion (gross) at 25°C, J/g <sup>b</sup>	22,662
flammable limits in air, vol %	
lower	6.0 <sup>c</sup>
upper	36 <sup>c</sup>
autoignition temperature, °C	464 <sup>c</sup>
flash point, closed cup, °C	11 <sup>c</sup>
surface tension at 25°C, mN/m(= dyn/cm)	22.1
specific heat of vapor at 25°C, J/(g·K) <sup>b</sup>	1.370
specific heat of liquid at 25°C, J/(g·K) <sup>b</sup>	2.533
vapor pressure at 25°C, kPa <sup>a</sup>	16.96
solubility in water	miscible
density at 25°C, g/mL	0.7866
refractive index, $n_D^{20}$	1.3284
liquid viscosity at 25°C, mPa·s(=cP)	0.541
dielectric constant at 25°C	32.7
thermal conductivity at 25°C, W/(m·K)	0.202

<sup>a</sup>To convert kPa to mm Hg, multiply by 7.5.

<sup>b</sup>To convert J to cal, divide by 4.184.

<sup>c</sup>Ref. 1.

### Chemical Reactions

Methanol undergoes reactions that are typical of alcohols as a chemical class (3). Dehydrogenation and oxidative dehydrogenation to formaldehyde over silver or molybdenum oxide catalysts are of particular industrial importance.

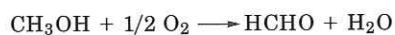

Acetic acid is produced by direct carbonylation of methanol in the presence of a homogeneous rhodium or cobalt catalyst.

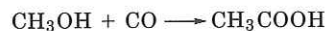

MTBE is produced from methanol and isobutylene in the liquid phase using an acidic catalyst:

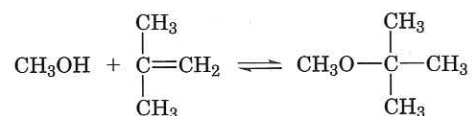

Methanol can be dehydrated over an acidic catalyst to give dimethyl ether and water:

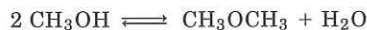

Methylamines are produced from the vapor reaction of methanol with ammonia over a silica-alumina catalyst. Methyl esters result from the reaction of methanol with the corresponding organic or inorganic acid as shown, eg, for methyl methacrylate.

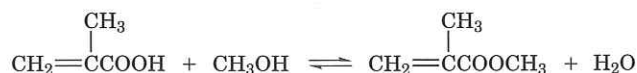

### Manufacture and Processing

Synthetic methanol production first began in 1923 at BASF's Leuna, Germany, plant, utilizing a zinc-chromium oxide catalyst (4). The activity of this catalyst required that it be operated at 25–35 MPa (250–350 atm) and 320–450°C. This high pressure process suffered from high capital and compression energy costs, compounded by poor catalyst selectivity. The high synthesis pressure also mandated use of reciprocating compressors, and limited single-train plant size to about 450 t/d.

The high pressure process was rendered obsolete in the mid-1960s when ICI in the United Kingdom developed a more active copper-zinc-alumina catalyst that could operate at 5–10 MPa (50–100 atm) and 210–270°C with higher selectivity and stability (5). Lurgi developed a similar catalyst and demonstrated its own process in Germany in the early 1970s, featuring a tubular steam-raising reactor (6). The resulting low pressure process revolutionized the industry, allowing more energy-efficient and cost-effective plants to be built with single-train capacities over 2200 t/d utilizing centrifugal compressors.

The energy consumption (lower heating value of the feedstock plus fuel) of the low pressure process has successively improved from over 38.3 GJ/t when it was first introduced to 29.0–30.3 GJ/t by the mid-1990s. Natural gas-based reforming plants have advanced to the point where the scope for still further gains in efficiency is small and the gains costly to obtain.

**Thermodynamics and Kinetics.** The synthesis reactions are as follows.

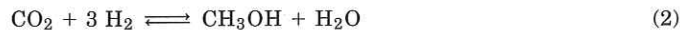

Subtracting reaction (2) from reaction (1) gives the familiar water gas shift reaction (eq. 3).



Because the synthesis reactions are exothermic with a net decrease in molar volume, equilibrium conversions of the carbon oxides to methanol by reactions

1 and 2 are favored by high pressure and low temperature, as shown for the indicated reformed natural gas composition in Figure 1. The mechanism of methanol synthesis on the copper-zinc-alumina catalyst was elucidated as recently as 1990 (7). For a pure  $H_2$ -CO mixture, carbon monoxide is adsorbed on the copper surface where it is hydrogenated to methanol. When  $CO_2$  is added to the reacting mixture, the copper surface becomes partially covered by adsorbed oxygen by the reaction  $CO_2 \rightleftharpoons CO + O(ads)$ . This results in a change in mechanism where CO reacts with the adsorbed oxygen to form  $CO_2$ , which becomes the primary source of carbon for methanol.

The zinc oxide component of the catalyst serves to maintain the activity and surface area of the copper sites, and additionally helps to reduce light ends by-product formation. Selectivity is better than 99%, with typical impurities being ethers, esters, aldehydes, ketones, higher alcohols, and waxes. The alumina portion of the catalyst primarily serves as a support.

The catalyst deactivates primarily because of loss in the active copper metal area according to the following mechanisms: physical blockage of the active sites by large by-product molecules; poisoning by halogens or sulfur in the synthesis gas, which irreversibly form inactive copper salts; and sintering of the copper crystallites into larger crystals, which then have a lower surface-to-volume ratio.

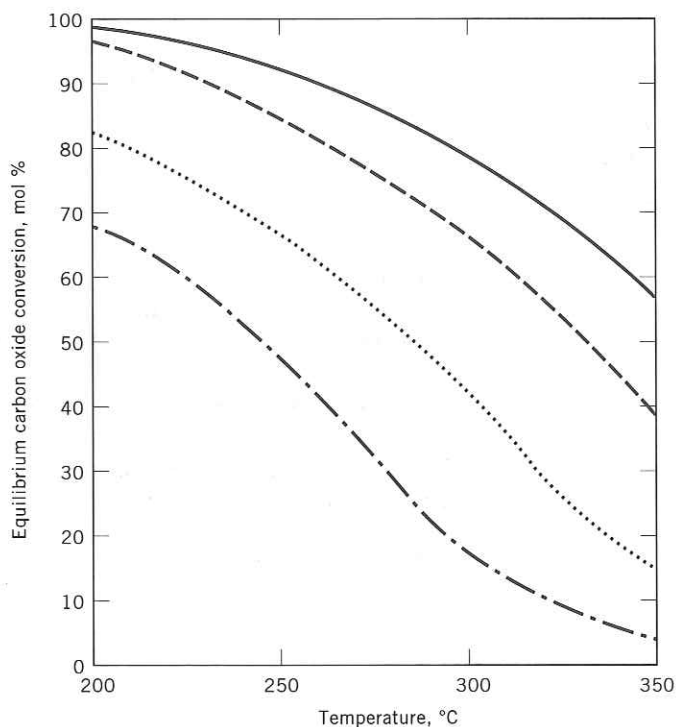

**Fig. 1.** Equilibrium conversion of carbon oxides to methanol based on reformed natural gas composition of 73%  $H_2$ , 15%  $CO$ , 9%  $CO_2$ , and 3%  $CH_4$  where (—) is at 30 MPa, (---) is at 20 MPa, (····) is at 10 MPa, and (-·-·) is at 5 MPa. To convert MPa to atm, multiply by 9.87.

Selectivity is primarily a function of temperature. The amount of by-products tends to increase as the operating temperature is raised to compensate for declining catalyst activity. By-product formation is also influenced by catalyst impurities, whether left behind during manufacture or otherwise introduced into the process. Alkaline impurities catalyze higher alcohol production whereas acidic impurities, as well as trace iron and nickel, promote heavier hydrocarbon formation.

**Synthesis Gas Generation Routes.** Any hydrocarbon that can be converted into a synthesis gas by either reforming with steam (eq. 4) or gasification with oxygen (eq. 5) is a potential feedstock for methanol.

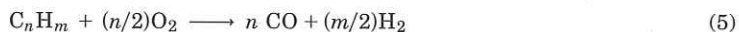
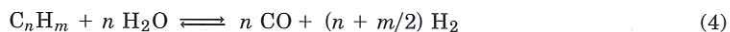

These reactions show that the synthesis gas stoichiometry is dependent on both the nature of the feedstock as well as the generation process. Reactions 4 and 5, together with the water gas shift reaction 3, serve to independently determine the equilibrium composition of the synthesis gas.

*Steam Reforming of Natural Gas.* This route accounts for at least 80% of the world's methanol capacity. A steam reformer is essentially a process furnace in which the endothermic heat of reaction is provided by firing across tubes filled with a nickel-based catalyst through which the reactants flow. Several mechanical variants are available (see AMMONIA).

Natural gas contains both organic and inorganic sulfur compounds that must be removed to protect both the reforming and downstream methanol synthesis catalysts. Hydrodesulfurization across a cobalt or nickel molybdenum-zinc oxide fixed-bed sequence is the basis for an effective purification system. For high levels of sulfur, bulk removal in a liquid absorption-stripping system followed by fixed-bed residual clean-up is more practical (see SULFUR REMOVAL AND RECOVERY). Chlorides and mercury may also be found in natural gas, particularly from offshore reservoirs. These poisons can be removed by activated alumina or carbon beds.

The reformer outlet composition is determined by an approach to the simultaneous equilibria of reactions 3 and 4, where  $m = 2n + 2$  represents the paraffinic nature of natural gas. The stoichiometry of the reformed gas can be conveniently characterized by the ratio  $R$ , where

$$R = \frac{H_2 - CO_2}{CO + CO_2}$$

because it is independent of the water gas shift reaction. Therefore,  $R = (2n + 1)/n$  for natural gas reforming. Methanol synthesis stoichiometry by reactions 1 or 2 requires that  $R = 2$ . This results in a mole of excess hydrogen being generated for each mole of methanol produced by reforming methane, for which  $n = 1$  and  $R = 3$ .

This excess hydrogen is normally carried forward to be compressed into the synthesis loop, from which it is ultimately purged as fuel. Addition of by-product  $CO_2$  where available may be advantageous in that it serves to adjust the

reformed gas to a more stoichiometric composition gas for methanol production, which results in a decrease in natural gas consumption (8). Carbon-rich off-gases from other sources, such as acetylene units, can also be used to provide supplemental synthesis gas. Alternatively, the hydrogen-rich purge gas can be an attractive feedstock for ammonia production (9).

The strongly endothermic reforming reaction (eq. 4) is favored by high temperatures and low pressures. Methanol plant reformers typically operate with exit temperatures within the 840–880°C range, the upper limit being determined by the tube metallurgy. Typical reformer pressures in the range 1–2 MPa (10–20 atm) are a reasonable compromise between residual methane content and downstream compression requirements. A stoichiometric molar excess steam-to-feedstock carbon ratio of 2.5 to 3.0 is used to give good reformer conversions and prevent undesirable carbon-forming side reactions.

Heat from the high temperature process and reformer flue gases is recovered into the plant steam system to provide motive power for compressors and large pumps, process steam for reforming, and reboil duty for distillation. The overall strategy for energy integration is to recover waste heat at the highest levels into the motive steam system to satisfy power requirements, and to minimize additional fuel firing to raise lower level process or reboiler steam.

*Steam Reforming of Naphtha.* Naphtha reforming is very similar to natural gas reforming, except that naphtha must be vaporized prior to the desulfurization step. Naphtha often contains higher levels of sulfur than natural gas, and more extensive purification is usually required. The larger molecules in naphtha decompose more readily than methane, increasing the risk of carbon deposition on the catalyst. Naphtha-reforming catalysts contain potash promoters which help suppress carbon-forming cracking reactions. Naphtha reforming produces a near-stoichiometric synthesis gas for methanol production. Presently there is no significant methanol production from this feedstock owing to the high relative cost of naphtha.

*Combined Reforming.* Combined reforming splits the total reforming duty between a conventional fired reformer and a downstream catalytic secondary reformer (Fig. 2) (10). The secondary reformer is a refractory-lined adiabatic vessel filled with a high temperature nickel reforming catalyst. Oxygen is used as the oxidant to provide the heat of the reforming reaction within the process itself by a combination of reactions 4 and 5. Air cannot be used, because the contained nitrogen would accumulate as an inert gas in the downstream methanol synthesis loop. By shifting a significant portion of the reforming duty away from the primary reformer, a near-stoichiometric ( $R = 2$ ) synthesis gas can be pro-

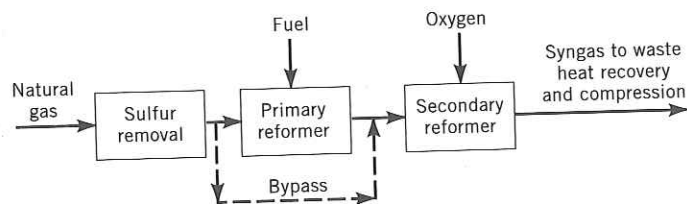

Fig. 2. Combined reforming.



duced, with low residual methane. The cost and attendant firing of the primary reformer are also reduced.

With this arrangement, the primary reformer can be designed to operate at higher pressures and lower temperatures, since the residual methane will be further reduced to low levels at the higher operating temperature of the secondary reformer, leading to a decrease in compression requirements and a reduction in the overall energy consumption of the plant. The combined reforming concept has also been employed to use high pressure primary reformers salvaged from old ammonia plants to provide synthesis gas for methanol plants (11).

*Gas-Heated Reforming.* Gas-heated reforming is an extension of the combined reforming concept where the primary reformer is replaced by a heat-transfer device in which heat for the primary reforming reaction is recovered from the secondary reformer effluent. Various mechanical designs have been proposed which are variants of a shell-and-tube heat exchanger (12,13).

The ICI Gas-Heated Reformer (GHR) shown in Figure 3 is one example of a reforming exchanger design that has been commercialized in a 450-t/d ammonia plant (13). The reforming catalyst is contained in scabbard tubes, each with a central bayonet tube with a thin outer sheath tube. The desulfurized natural gas and steam feed enters through the top of the vessel in between the boxed tube sheets and into the scabbard tubes. The gas flows down the catalyst-packed annular space between the scabbard and bayonet tubes before passing back up the bayonet tube to the top of the GHR and exiting to the secondary reformer. The inside of the bayonet tubes is insulated to maximize heat exchange with the secondary reformer effluent. The hot secondary reformer effluent flows up the shell of the GHR.

The ICI Leading Concept Methanol (LCM) process incorporating a GHR and oxygen blown secondary reformer is shown schematically in Figure 4. This process was commercialized in Australia in 1994 (14).

*Other Synthesis Gas Generation Processes.* Synthesis gas can be generated from coal and petroleum fractions by a variety of processes (see COAL CONVERSION PROCESSES, GASIFICATION; HYDROGEN). Because of the low hydrogen-to-carbon ratios of these feedstocks ( $m/n$  in reactions 4 and 5), the synthesis gas produced has an excess of carbon ( $R < 2$ ) for methanol synthesis. Therefore, processes based on these feedstocks share the common feature of carbon removal to adjust the stoichiometry of the raw synthesis gas (Fig. 5). This requires part of the synthesis gas to be diverted to a converter where carbon monoxide is shifted with steam to hydrogen and carbon dioxide by reaction 3. The excess carbon in the form of carbon dioxide is then removed by scrubbing, and the resulting gas streams are combined to give the stoichiometry required by methanol synthesis. Raw gas cleanup is also required to remove contaminants that are either present in the raw materials or are formed from them.

The high cost of coal handling and preparation and treatment of effluents, compounded by continuing low prices for crude oil and natural gas, has precluded significant exploitation of coal as a feedstock for methanol. A small amount of methanol is made from coal in South Africa for local strategic reasons. Tennessee Eastman operates a 195,000-t/yr methanol plant in Tennessee based on the Texaco coal gasification process to make the methyl acetate intermediate for acetic anhydride production (15).

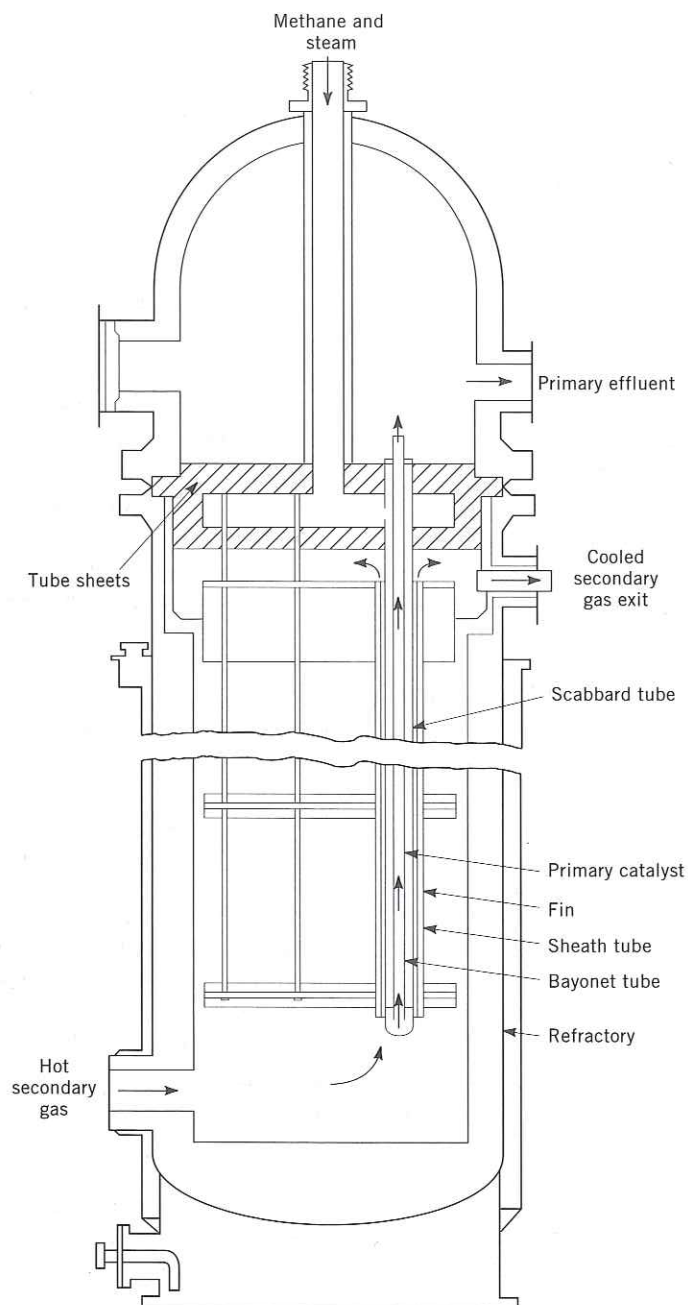

Fig. 3. ICI gas heated reformer (13).

Noncatalytic partial oxidation of residual fuel oil accounts for the remainder of world methanol production. Shell and Texaco are the predominant licensors for partial oxidation technology (16); the two differ principally in the mechanical details of mixing the feedstock and oxidant, in waste heat recovery, and in solids management.

Natural g

N  
c

Coal or fu  
oil feed

Oxygen

M  
thesis  
flow s  
typical  
gives  
can be  
T  
prehea  
conver  
being r

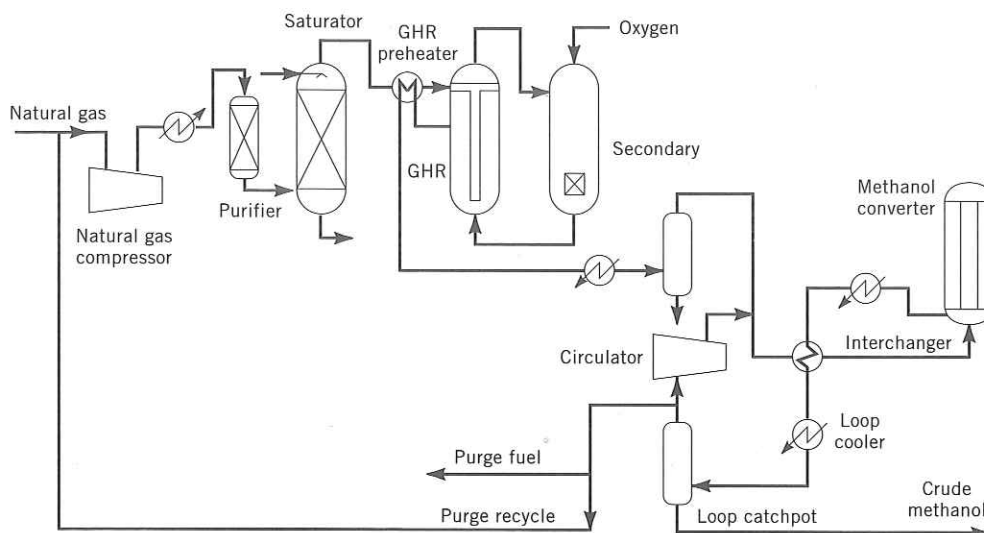

Fig. 4. ICI LCM process.

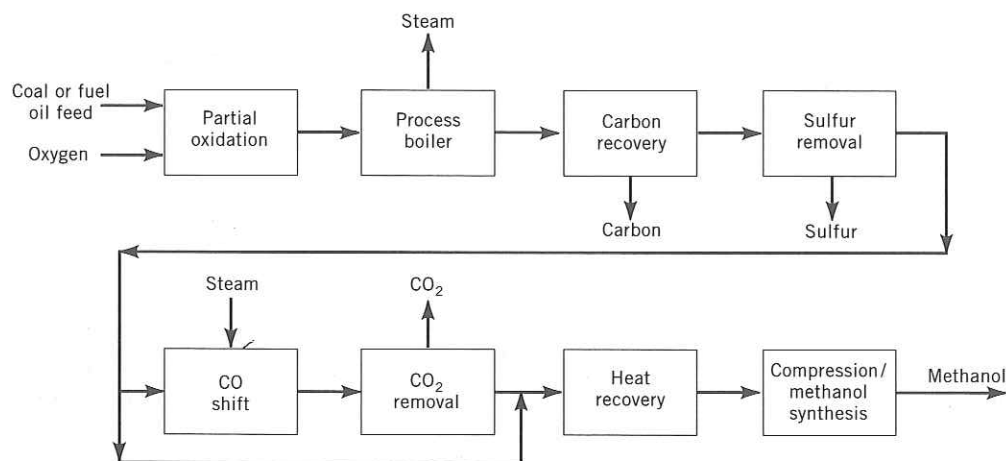

Fig. 5. Processing sequence for methanol from coal or fuel oil.

**Methanol Synthesis.** All commercial methanol processes employ a synthesis loop, and Figure 6 shows a typical example as part of the overall process flow sheet. This configuration overcomes equilibrium conversion limitations at typical catalyst operating conditions as shown in Figure 1. A recycle system that gives high overall conversions is feasible because product methanol and water can be removed from the loop by condensation.

The makeup synthesis gas is compressed, mixed with recycled gas, and preheated against the converter effluent gas before entering the converter. The converter effluent is first used to heat saturator water or boiler feedwater before being returned to the loop interchanger and then on to a cooler which condenses

the crude methanol catchpot for removing water, methane, and other light ends by distillation. The feed to the distillation processes from the methanol converter in use are shown in Figure 6. Commercially available types or a combination of types. Quench water is used in the initial ICI low temperature process and recycle fractions for the inlet temperature of the inlet tem

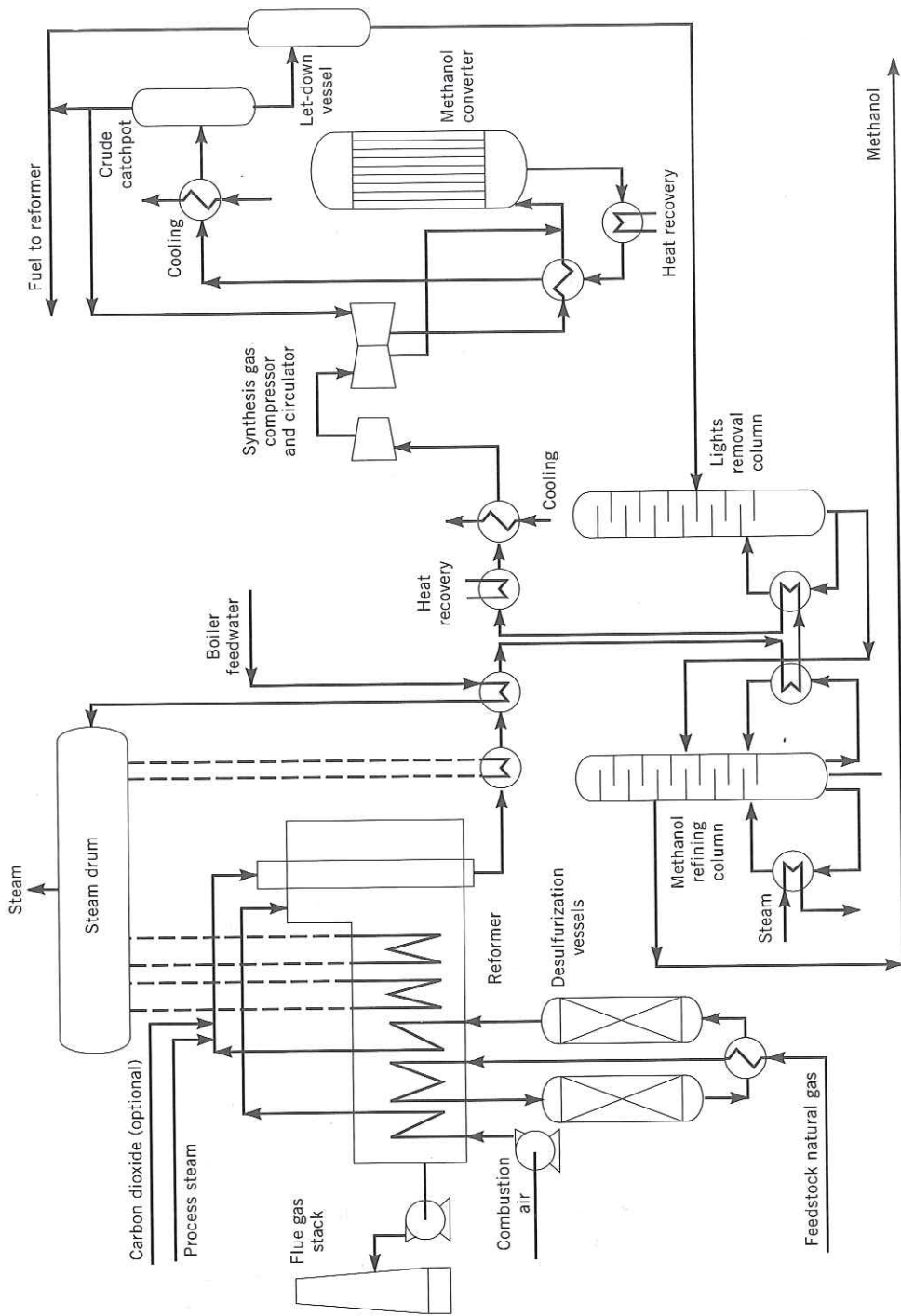

Fig. 6. Methanol synthesis process flow sheet.

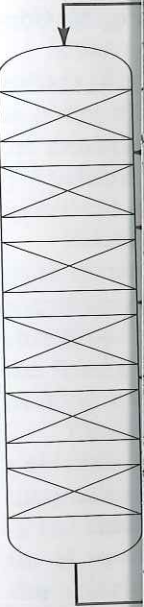

Fig. 7. Me and (d) stea

the crude methanol-water mixture. Noncondensable gases are disengaged in a catchpot for recycle. A purge is taken from this recycle to remove excess hydrogen, methane, and other inerts. The crude methanol mixture is sent forward to the distillation section for final purification.

The feature that is most useful in distinguishing commercial methanol processes from one another is the type of reactor used. The four basic types in use are shown in Figure 7. There are a variety of proprietary reactor designs commercially available from licensors, all of which are either one of these four types or a combination of two among them (17-22).

**Quench Converter.** The quench converter (Fig. 7a) was the basis for the initial ICI low pressure methanol flow sheet. A portion of the mixed synthesis and recycle gas bypasses the loop interchanger, which provides the quench fractions for the intermediate catalyst beds. The remaining feed gas is heated to the inlet temperature of the first bed. Because the beds are adiabatic, the feed

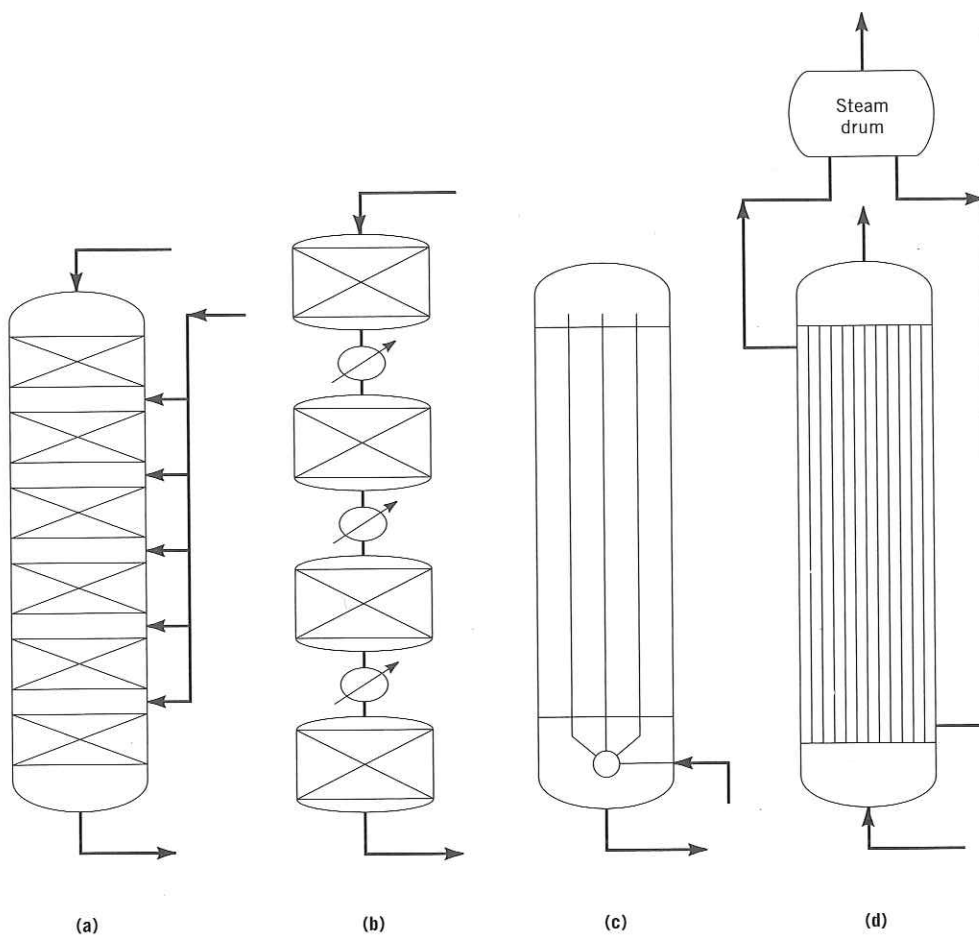
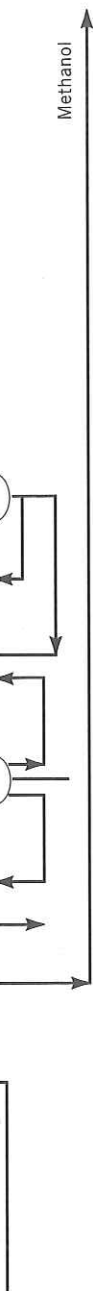

Fig. 7. Methanol converter types: (a) quench, (b) multiple adiabatic, (c) tube-cooled, and (d) steam-raising.

Fig. 6. Methanol synthesis process flow sheet.



gas temperature increases as the exothermic synthesis reactions proceed. The injection of quench gas between the beds serves to cool the reacting mixture and add more reactants prior to entering the next catalyst bed. Quench converters typically contain three to six catalyst beds with a gas distributor in between each bed for injecting the quench gas. A variety of gas mixing and distribution devices are employed which characterize the proprietary converter designs.

Figure 8 shows the characteristic sawtooth temperature profile which represents the thermodynamic inefficiency of this reactor type as deviations from the maximum reaction rate. Catalyst productivity is further reduced because not all of the feed gas passes through all of the catalyst. However, the quench converter has remained the predominant reactor type with a proven record of reliability.

*Adiabatic Converters.* The adiabatic converter system employs heat exchangers rather than quench gas for interbed cooling (Fig. 7b). Because the beds are adiabatic, the temperature profile still exhibits the same sawtooth approach to the maximum reaction rate, but catalyst productivity is somewhat improved because all of the gas passes through the entire catalyst volume. Costs for vessels and exchangers are generally higher than for quench converter systems.

*Tube-Cooled Converter.* The tube-cooled converter functions as an interchanger, consisting of a tube-filled vessel with catalyst on the shell side (Fig. 7c). The combined synthesis and recycle gas enters the bottom of the reactor tubes, where it is heated by the reaction taking place in the surrounding catalyst bed. The gas turns at the top of the tubes and passes down through the catalyst bed. The principal advantage of this converter is in the reduced catalyst volume, since the reaction path more closely follows the maximum rate line (Fig. 9). Con-

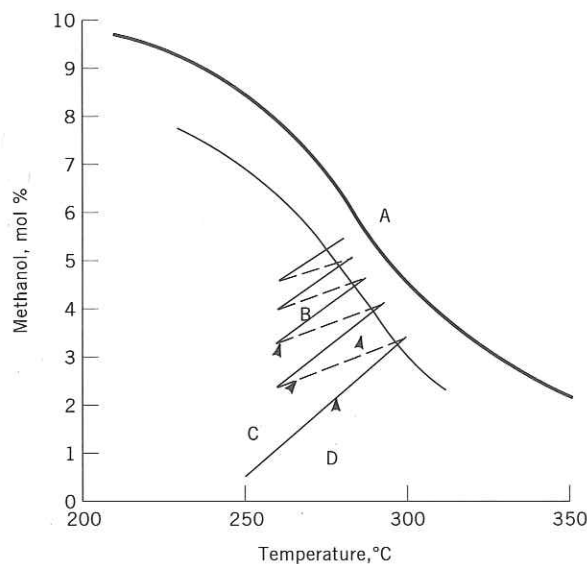

**Fig. 8.** Quench converter temperature profile. A, equilibrium line; B, maximum rate line; C, quench line; and D, intrabed line.

proceed. The  
g mixture and  
ch converters  
or in between  
d distribution  
r designs.

ile which rep-  
viations from  
duced because  
r, the quench  
ven record of

loys heat ex-  
ause the beds  
both approach  
that improved  
sts for vessels  
stems.

s as an inter-  
side (Fig. 7c).  
reactor tubes,  
catalyst bed.  
n the catalyst  
catalyst volume,  
(Fig. 9). Con-

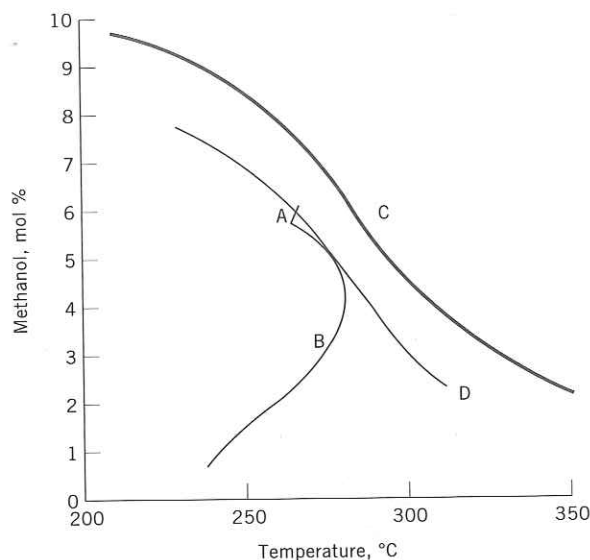

Fig. 9. Tube-cooled converter temperature profile. A, adiabatic bed; B, tube-cooled bed; C, equilibrium line; and D, maximum rate line.

verter performance can further be enhanced by extending the catalyst below the tube-cooled area to act as a further adiabatic reaction zone.

**Steam-Raising Converter.** There are a variety of tubular steam-raising converters (Fig. 7d) available, which feature radial or axial flow, with the catalyst on either shell or tube side. The near-isothermal operation of this reactor type is the most thermodynamically efficient of the types used, requiring the least catalyst volume. Lower catalyst peak temperatures also result in reduced by-product formation and longer catalyst life.

Retrofitting features of the more efficient reactor types have been the principal thrust of older methanol plant modernization (17). Conversion of quench converters to radial flow improves mixing and distribution, while reducing pressure drop. Installing an additional converter on the synthesis loop purge or before the final stage of the synthesis gas compressor has been proposed as a debottlenecking measure.

**Final Purification.** Crude methanol is purified by a conventional distillation train of one to three towers, depending on the purity and degree of heat integration desired. Methanol and higher alcohols tend to bulge near the bottom of the final distillation column, and are withdrawn and burned as fuel. The water of reaction 2 exits the base of the final distillation column, and represents the principal process effluent. By using this water to saturate the natural gas feedstock to provide part of the reforming steam, organics in this stream are recycled to extinction, further reducing pollution potential.

With these waste-minimization techniques, methanol synthesis is relatively clean, and poses no unique environmental hazards. The need for environmental controls is more closely associated with the synthesis gas generation process.

**Future Methanol Processes.** The process route for methanol synthesis has remained basically unchanged since its inception by BASF in 1923. The principal developments have been in catalyst formulation to increase productivity and selectivity, and in process plant integration to improve output and energy efficiency while decreasing capital cost.

A fundamentally different reaction system is under development by Air Products and Chem Systems (23). In this system, synthesis gas is bubbled through a slurry consisting of micrometer-sized methanol catalyst particles suspended in a paraffinic mineral oil. The liquid phase serves as the heat sink to remove the heat of reaction.

Direct conversion of methane [74-82-8] to methanol has been the subject of academic research for over a century. The various catalytic and noncatalytic systems investigated have been summarized (24,25). These methods have yet to demonstrate sufficient advantage over the conventional synthesis gas route to methanol to merit a potential for broad use.

Two developments appear to be the most promising in attaining this elusive goal (26). Catalytica Inc. is developing a homogeneous mercury-catalyzed process based on the reaction of methane with sulfuric acid to form a methyl bisulfate intermediate, which can then be hydrolyzed to methanol. The sulfuric acid co-product is recycled. Additionally, researchers at the University of Minnesota are investigating using platinum- and rhodium-based catalysts to make synthesis gas from methane and oxygen in an autothermal reactor that eliminates the requirement for extensively preheating the feed gases.

### Health and Safety

Methanol is not classified as carcinogenic, but can be acutely toxic if ingested; 100–250 mL may be fatal or result in blindness. The principal physiological effect is acidosis resulting from oxidation of methanol to formic acid. Methanol is a general irritant to the skin and mucous membranes. Prolonged skin contact with methanol vapor or liquid can cause dermatitis. Methanol vapor can cause eye and respiratory tract irritation, nausea, headaches, and dizziness.

Methanol does not pose an undue toxicity hazard if handled in well-ventilated areas, and is rated as a slight health hazard by the National Fire Protection Association (NFPA). The TLV is 200 ppm with a STEL of 250 ppm, and the limit which is immediately dangerous to life and health is 25,000 ppm. Accidental ingestion is immediately treated by inducing vomiting, followed by administration of sodium bicarbonate. Rinsing with water is effective in treating external exposure.

### Storage and Handling

Methanol is stable under normal storage conditions. Methanol is not subject to hazardous polymerization reactions, but can react violently with strong oxidizing agents. The greatest hazard involved in handling methanol is the danger of fire or explosion. The NFPA classifies methanol as a serious fire hazard.

Equip  
stainless s  
and alumi  
chosen ca  
to methar

Both  
age. Blan  
system m  
precludes  
vented ta  
the ingre  
storage ta  
event of :

Norm  
observed,  
presented  
small lea  
For small  
fires may  
and load  
accumula

Met  
safety an  
with app  
may be c  
never wi

Per  
tection fr  
lenses sh  
trate me  
with ade

### Econom

The nan  
Table 2  
feedstoc  
mid-199  
to come  
oil prod  
of a sub  
transport  
it is for

Hig  
to large  
unplann  
distance



Equipment for storing and handling methanol may be made of carbon or stainless steel. Methanol is aggressive toward copper, zinc, magnesium, tin, lead, and aluminum, which should therefore be avoided. Gasket materials must also be chosen carefully, because some elastomers swell and deteriorate when exposed to methanol. Similarly, the use of plastics for storage is not recommended.

Both floating- and fixed-roof tanks are used for large-scale methanol storage. Blanketing the tank vapor space in combination with a closed vent recovery system may be required by local environmental regulations. This system also precludes formation of flammable mixtures that could form in atmospherically vented tanks, and helps assure the integrity of product quality by eliminating the ingress of atmospherically borne moisture and other contaminants. Fitting storage tanks with frangible tops helps protect the tank walls from failing in the event of an internal explosion.

Normal precautions for storing and handling flammable liquids should be observed, such as diking and fire fighting provisions. Additional hazards are presented by the mild odor and water-like appearance of methanol, which makes small leaks hard to detect, and the nearly invisible flame of burning methanol. For small fires, water or chemical extinguishing agents are adequate. Larger fires may require alcohol-resistant foams for control. Grounding for tankage and loading facilities is advisable to protect against lightning strikes and the accumulation of static electricity.

Methanol is shipped overland by tank cars, trucks, and drums. The same safety and materials considerations apply to each of these types of containers, with appropriate labeling required by local and Federal authorities. Methanol may be off-loaded either by pumps or by pressurizing it with an inert gas, but never with air.

Personnel involved in the handling of methanol require eye and skin protection from the irritating properties of methanol in the event of a spill. Contact lenses should not be worn, since plastic lens materials may absorb and concentrate methanol against the eye. Additional respiratory protection is not required with adequate local explosion-proof ventilation.

### Economic Aspects

The nameplate capacity of worldwide methanol plants is given by country in Table 2 (27). A significant portion of this capacity is based on natural gas feedstock. Percent utilization is expected to remain in the low 90s through the mid-1990s. A principal portion of this added capacity is expected to continue to come from offshore sources where natural gas, often associated with crude oil production, is valued inexpensively. This has resulted in the emergence of a substantial international trade in methanol. In these cases, the cost of transportation is a relatively larger portion of the total cost of production than it is for domestic plants.

High percentage capacity utilizations will make methanol prices vulnerable to large fluctuations owing to supply-and-demand imbalances resulting from unplanned production outages. This situation is compounded by lengthy shipping distances from remote large producers, putting additional pressure on prices.

**Table 2. Estimated World Methanol Annual Nameplate Production Capacity, 1993**

Country	Nameplate capacity, 10 <sup>3</sup> t
United States	5,300
Canada	2,428
Mexico	210
Germany	1,610
the Netherlands	740
United Kingdom	500
China	900
India	272
Indonesia	330
Iran	120
Japan	270
Malaysia	660
New Zealand	880
Argentina	87
Brazil	188
Chile	750
Trinidad	1,000
Algeria	110
Bahrain	425
Israel	55
Libya	660
Saudi Arabia	2,090
South Africa	26
CIS	2,790
<i>World total</i>	<i>22,401</i>

## Uses

World methanol consumption for 1992 is shown in Figure 10 (27). The principal use of methanol has traditionally been in the production of formaldehyde [50-00-0], where typically around 40% of the world methanol market is consumed. In the United States, an increasing role for methanol has been found in the oxygenated fuels market from the use of MTBE. Another significant use of methanol is in the production of acetic acid; other uses include the production of solvents and chemical intermediates.

**Formaldehyde.** Worldwide, the largest amount of formaldehyde (qv) is consumed in the production of urea-formaldehyde resins, the primary end use of which is found in building products such as plywood and particle board (see AMINO RESINS AND PLASTICS). The demand for these resins, and consequently methanol, is greatly influenced by housing demand. In the United States, the greatest market share for formaldehyde is again in the construction industry. However, a fast-growing market for formaldehyde can be found in the production of acetylenic chemicals, which is driven by the demand for 1,4-butanediol and its subsequent downstream product, spandex fibers (see FIBERS, ELASTOMERIC).

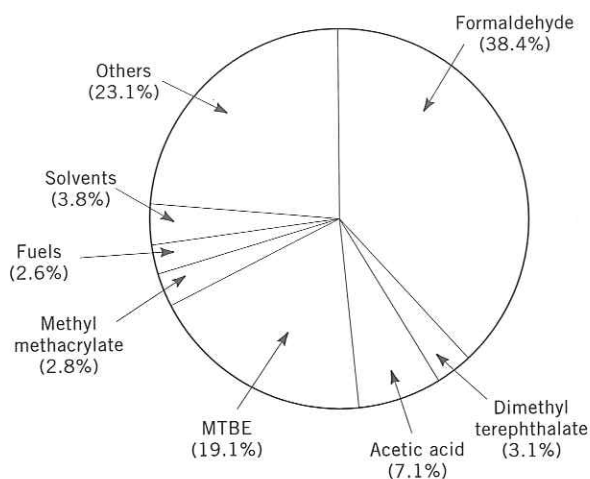

Fig. 10. World methanol demand, 1992. Total = 19,577,000 t.

**Methyl *t*-Butyl Ether.** MTBE is used as an oxygen additive for gasoline. Production of MTBE in the United States has increased due to the requirements of the 1990 Clean Air Act amendments, and has surpassed formaldehyde as the largest domestic consumer of methanol. Projections for this use of methanol are difficult to estimate due to the varying political and environmental considerations that promote the use of cleaner burning motor fuels (see ETHERS).

**Acetic Acid.** Methanol carbonylation has become the process of choice for production of this staple of the organic chemical industry, which is used in the manufacture of acetate fibers, acetic anhydride [108-24-7], and terephthalic acid, and for fermentation (see ACETIC ACID AND DERIVATIVES).

**Other Markets.** The use of methanol in the production of formaldehyde, MTBE, and acetic acid [64-19-7] accounts for approximately two-thirds of the worldwide demand for methanol. Methanol is used as feedstock for various other chemicals, such as dimethyl terephthalate (DMT) [120-61-6], methyl methacrylate [80-62-6], methylamines, and methyl halides. The interest in the production of dimethyl ether [115-10-6] from methanol is growing as a result of its use as a replacement for chlorofluorocarbons as an aerosol propellant. Methanol also finds use as a solvent, as an antifreeze in pipelines, and in drilling mud in oil fields.

Direct fuel applications of methanol have not grown as anticipated (see ALCOHOL FUELS). It is used in small quantities in California and other locations, primarily for fleet vehicle operation. Large-scale use of methanol as a direct fuel is not anticipated until after the year 2000. Methanol continues to be utilized in the production of gasoline by the Mobil methanol-to-gasoline (MTG) process in New Zealand. A variant of this process has also been proposed to produce olefins from methanol.

**Future Uses.** The most recent uses for methanol can be found in the agricultural sector. Test studies are being carried out where methanol is sprayed directly onto crops to improve plant growth. Methanol can be used as a carbon

The principal  
dehyde [50-00-  
sumed. In the  
the oxygenated  
methanol is in  
of solvents and

dehyde (qv) is  
primary end use  
vehicle board (see  
consequently  
ed States, the  
tion industry.  
the production  
utanediol and  
ELASTOMERIC).

source for the production of single-cell protein (SCP) for use as an animal feed supplement. The process has been commercially demonstrated by ICI at their Billingham, U.K., facility. However, the production of SCP is not commercially practical at this time, in comparison to more conventional protein sources.

Denitrification of wastewater in treatment plants offers another potential use for methanol. There are a few such plants in the world; however, this use is not expected to grow appreciably, as there are more proven methods for nitrogen removal commercially available.

### Specifications

The methanol market evolved on more of a local basis, without a universal product standard. Federal Specification O-M-232, developed by the General Services Administration for governmental purchase of methanol, became a commonly accepted standard. This specification sets requirements for Grade A methanol, intended for solvent use, and Grade AA, intended for hydrogen or carbon dioxide generation. Grade AA differs from Grade A primarily in allowable ethanol, water, and acetone content. ASTM D1152 also provides a methanol standard. These three specifications are summarized in Table 3.

**Table 3. Methanol Specifications**

Parameter	Grade A	Grade AA	ASTM D1152
purity, wt %	99.85	99.85	99.85
specific gravity <sup>a</sup>	0.7928	0.7928	0.7920–0.7930 0.7883–0.7893 <sup>b</sup>
distillation range, °C	1.0 (incl. 64.6 ± 0.1)	1.0 (incl. 64.6 ± 0.1)	1.0 (incl. 64.6 ± 0.1)
color (Pt–Co, max)	5	5	5
odor	characteristic, nonresidual	characteristic, nonresidual	characteristic, nonresidual
carbonizable impurities (color, Pt–Co, max)	30	30	50
appearance	clear, no sediment	clear, no sediment	
nonvolatile content, mg/100 mL, max	1	1	5
permanganate time, min	30	30	50
acetone + aldehydes, wt %, max	0.003	0.003	
acetone, wt %, max		0.002	0.003
ethanol, wt %, max		0.001	
acidity, wt %, max	0.003	0.003	0.003
water, wt %, max	0.15	0.10	0.10
water miscibility	no turbidity	no turbidity	no turbidity

<sup>a</sup>At 20°C, unless otherwise indicated.

<sup>b</sup>At 25°C.

an animal feed  
ICI at their  
commercially  
sources.  
her potential  
er, this use is  
s for nitrogen

iversal prod-  
eral Services  
commonly ac-  
A methanol,  
carbon dioxide  
hanol, water,  
ndard. These

STM D1152  
99.85  
920-0.7930  
883-0.7893<sup>b</sup>  
incl. 64.6 ± 0.1)  
5  
characteristic,  
residual  
50  
5  
50  
0.003  
0.003  
0.10  
purity

The advent of a large international trade in methanol as a chemical feedstock has prompted additional purchase specifications, depending on the end user. Chlorides, which would be potential contaminants from seawater during ocean transport, are common downstream catalyst poisons likely to be excluded. Limitations on iron and sulfur can similarly be expected. Some users are sensitive to specific by-products for a variety of reasons. For example, alkaline compounds neutralize MTBE catalysts, and ethanol causes objectionable propionic acid formation in the carbonylation of methanol to acetic acid. Very high purity methanol is available from reagent vendors for small-scale electronic and pharmaceutical applications.

## BIBLIOGRAPHY

- "Methanol" in *ECT* 1st ed., Vol. 9, pp. 31-61, by W. W. Yeandle, B. H. Sanders, and H. C. Zeisig, Jr., Spencer Chemical Co.; in *ECT* 2nd ed., Vol. 13, pp. 370-398, by H. F. Woodward, Jr., Gulf Oil Corp.; in *ECT* 3rd ed., Vol. 15, pp. 398-415, by L. E. Wade, R. B. Gengelbach, J. L. Trumbley, and W. L. Hallbauer, Celanese Chemical Co., Inc.
1. *Fire Hazard Properties of Flammable Liquids, Gases, and Volatile Solids*, NFPA 325M, National Fire Protection Association, Quincy, Mass., 1991.
  2. L. H. Horseley, *Azeotropic Data II, Advances in Chemistry Series*, Vol. 116, American Chemical Society, Washington, D.C., 1973.
  3. J. A. Monick, *Alcohols, Their Chemistry, Properties, and Manufacture*, Reinhold Book Corp., New York, 1968, pp. 93-101.
  4. Ger. Pat. 293,787 (Mar. 8, 1913) (to BASF).
  5. P. L. Rogerson, *Chem. Eng. Symp. Ser. No. 98* **66**, 28 (1970).
  6. H. Hiller, F. Marschner, and E. Supp, *Chem. Econ. Eng. Rev.* **3**, 9 (1971).
  7. G. Chinchin, K. Mansfield, and M. Spenser, *Chemtech*, 692-699 (Nov. 1990).
  8. D. Mehta and D. Ross, *Hydrocarbon Process.* **49**(11), 183 (Nov. 1970).
  9. T. A. Czuppon and J. M. Lee, *Oil Gas J.* **85**(36), 42 (Sept. 7, 1987).
  10. G. L. Farina and E. Supp, *Hydrocarbon Process.* **71**(3), 77 (Mar. 1992).
  11. E. Supp and A. T. Weschler, "Conversion of Ammonia Plants to Methanol Production using Lurgi's Combined Reforming Technology", *AICHE 1992 Spring Meeting*, New Orleans.
  12. R. V. Schneider and J. R. LeBlanc, *Hydrocarbon Process.* **71**(3), 51 (Mar. 1992).
  13. *Nitrogen* **178**, 30-39 (Mar.-Apr. 1989).
  14. I. Rees, "BHP Petroleum's LCM Based Methanol Plant," *1993 World Methanol Conference*, Atlanta, Ga.
  15. H. W. Coover and R. C. Hart, *Chem. Eng. Progr.* **60**(4), 72 (1982).
  16. *Hydrocarbon Process.* **63**(4), 90 (Apr. 1984).
  17. *Oil Gas J.* **91**(13), 53-57 (Mar. 29, 1993).
  18. K. Westerterp and co-workers, *Hydrocarbon Process.* **67**(11), 69 (Nov. 1988).
  19. A. Zardi, *Hydrocarbon Process.* **61**(8), 129 (Aug. 1982).
  20. Makihara and co-workers, *Energy Progr.* **7**(1), 51 (Mar. 1987).
  21. Y. Kobayashi and H. Nakamura, "MRF Reactor, Commercially Proven Performance and Enhancement for Large Scale Methanol Plant," *AICHE 1993 Spring Meeting*, Houston, Tex.
  22. *Nitrogen* **205**, 38 (Sept.-Oct. 1993).
  23. R. L. Dickenson, A. J. Moll, and D. R. Simbeck, *Oil Gas J.* **80**, 242 (Mar. 8, 1982).
  24. S. Narula, "Economic Prospects for Methane Conversion Technologies", *AICHE 1989 Spring Meeting*, Houston, Tex.

25. H. Gesser, *Chem. Rev.* **85**(4), 235 (1985).
26. *Chem. Week* **152**(4), 15 (Jan. 27, 1993).
27. J. A. Crocco, "World Methanol Update," 1993 *World Methanol Conference*, Atlanta, Ga.

ALAN ENGLISH  
JERRY ROVNER  
John Brown

SIMON DAVIES  
Davy Process Technology

**METHIONINE.** See AMINO ACIDS.

**METHYL ACETATE.** See ACETIC ACID; ESTERS, ORGANIC.

**METHYLACETYLENE.** See HYDROCARBONS, ACETYLENE.

**METHYL ALCOHOL.** See METHANOL.

**METHYLAMINES.** See AMINES, LOWER ALIPHATIC.

**METHYL SULFATE.** See SULFURIC AND SULFUROUS ESTERS.

## MICA

Mica [12001-26-2] is a generic term that applies to a wide range of hydrous aluminum silicate minerals characterized by sheet or plant-like structure, and possessing to varying degrees, depending on composition and weathering, flexibility, elasticity, hardness (qv), and the ability to be split into thin (1  $\mu\text{m}$ ) sheets (1). All micas form flat six-sided monochromic crystals, and possess cleavage parallel to the basal plane.

Mica exists in nature in a wide variety of compositions (Table 1) (2). Muscovite and phlogopite are the only natural micas of commercial importance. Vermiculite, although not considered a true mica by most mineralogists, is a micaeous mineral formed from the weathering of phlogopite or biotite and is also of commercial importance. Fluorophlogopite,  $\text{K}_2\text{Mg}_6(\text{Al}_2\text{Si}_6\text{O}_{20})\text{F}_4$ , is a synthetic mica made from pure chemical oxides.